

STORTER FIRST MINOR SUBDIVISION - ROAD PLANS

(NE 1/4 OF NE 1/4 OF SECTION 29, TOWNSHIP 06 SOUTH, RANGE 01 E)

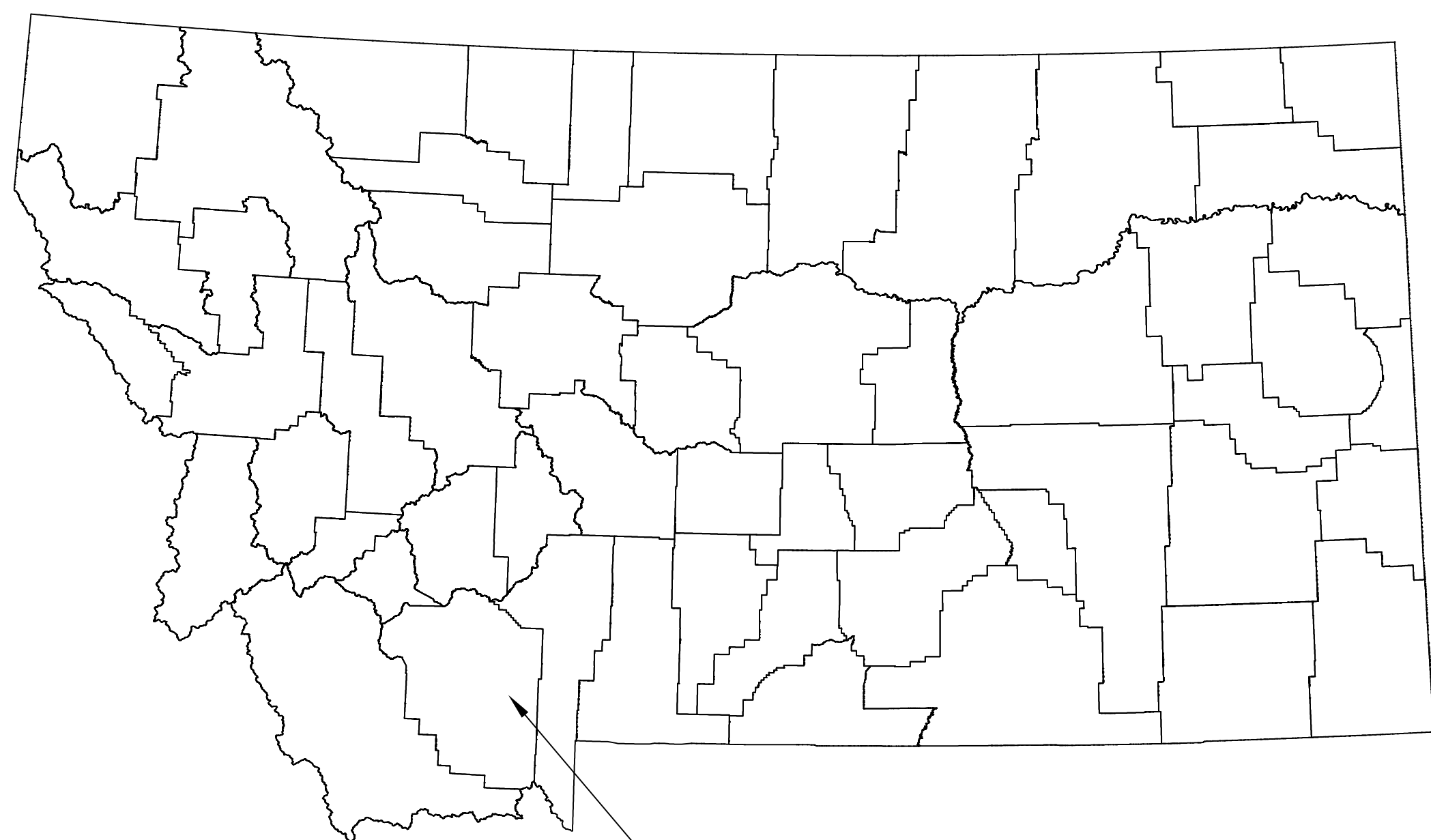

APPROXIMATE PROJECT LOCATION

OWNER

JOHNATHON STORTER
13320 RIDGEVIEW
ANCHORAGE, AK 99516

SHEET INDEX

- R1.0 - OVERALL ROAD PLAN
- R2.0 - MCDEED CREEK ROAD
- R2.1 - SONGBIRD WAY (0+00 TO 5+50)
- R2.2 - SONGBIRD WAY (5+50 TO 10+50)
- R3.0 - ROAD DETAILS

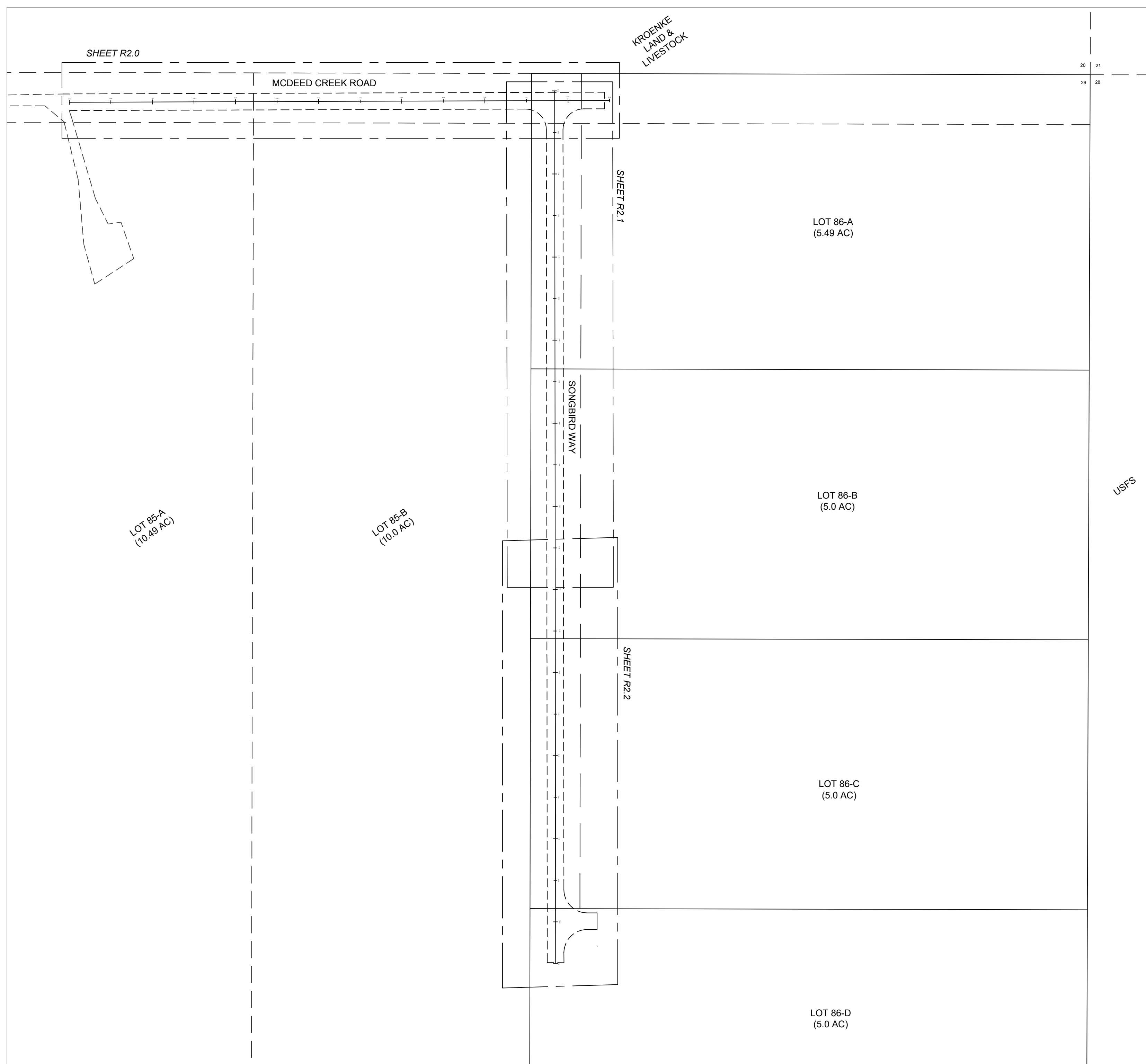
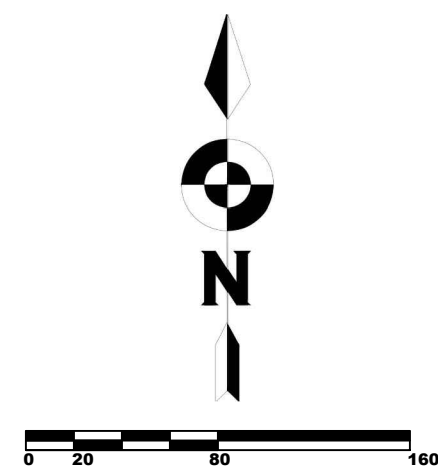

REVISIONS				
NO.	DESCRIPTION	DATE	BY	CHECKED BY

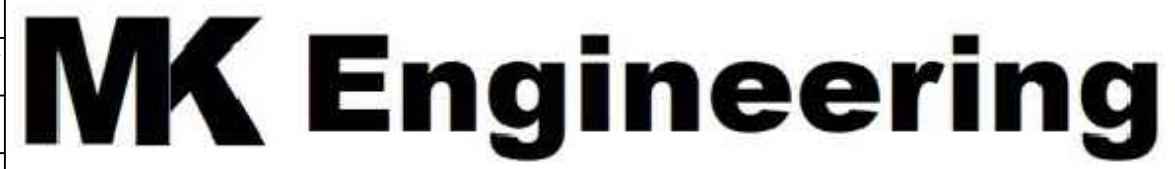

P.O. BOX 353
McALLISTER, MT 59740
(406) 570-0341
mkcivilengineering.com

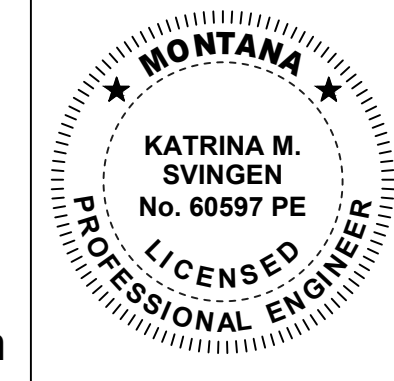

DESIGNED BY
DRAWN BY
DATE
QA / QC
CHECKED BY
DATE

STORTER MINOR SUBDIVISION
MADISON COUNTY, MT

ROAD PLANS
MCDEED CREEK ROAD

PROJECT NUMBER 24-102
SHEET NUMBER 1 OF 5
DRAWING NUMBER R1.0

STORTER FIRST MINOR SUBDIVISION - ROAD PLANS

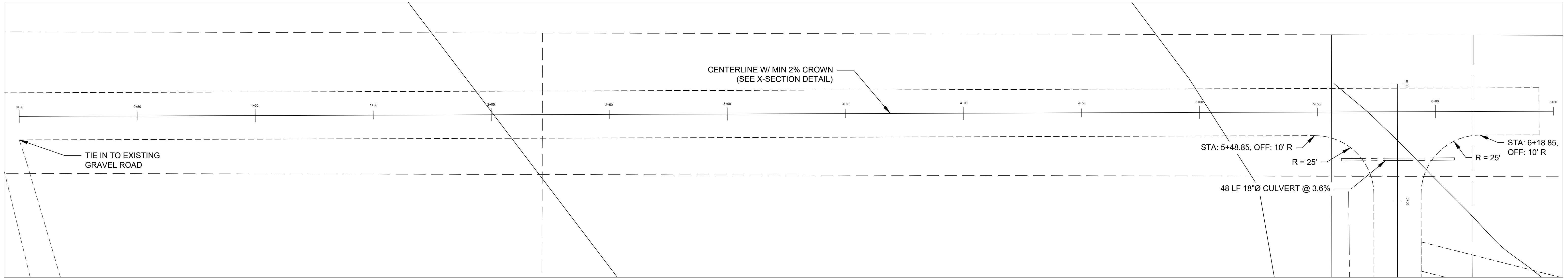

MCDEED CREEK ROAD PLAN

SCALE: 1" = 20'

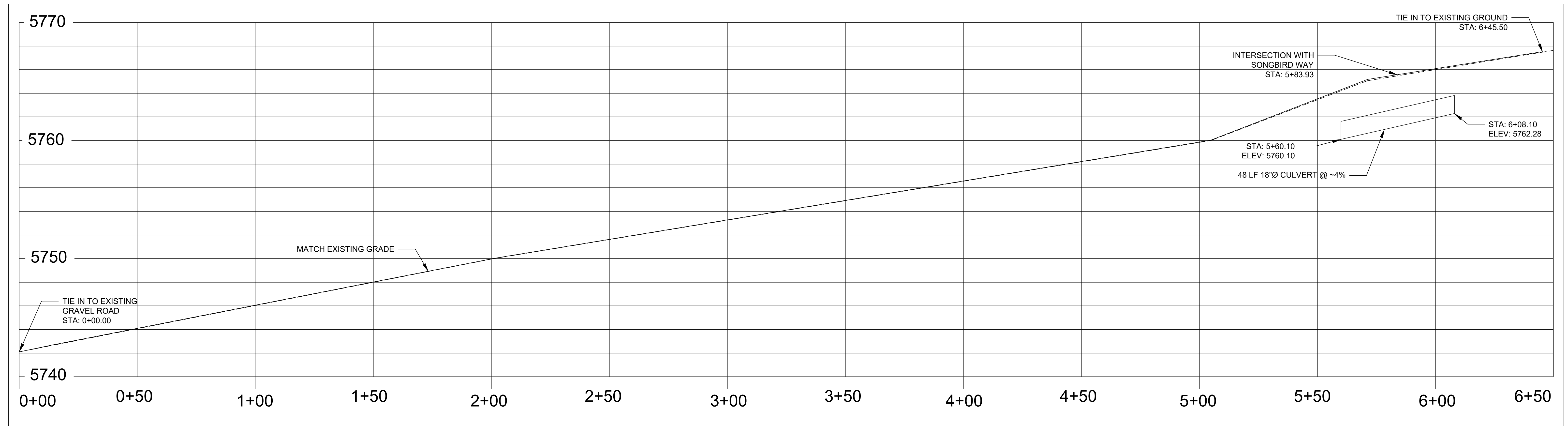

MCDEED CREEK ROAD PROFILE

HORIZONTAL SCALE: 1" = 20'
VERTICAL SCALE: 1" = 4'

REVISIONS

NO.	DESCRIPTION	DATE	BY	CHECKED BY

MK Engineering

P.O. BOX 353
McALLISTER, MT 59740

(406) 570-0341
mkcivilengineering.com

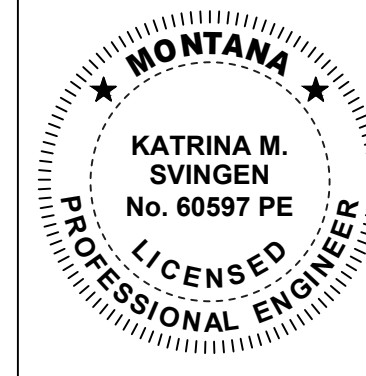

DESIGNED BY	
DRAWN BY	
DATE	
QA / QC CHECKED BY	
DATE	

STORTER MINOR SUBDIVISION

MADISON COUNTY, MT

ROAD PLANS MCDEED CREEK ROAD

PROJECT NUMBER
24-102

SHEET NUMBER
2 OF 5

DRAWING NUMBER

R2.0

STORTER FIRST MINOR SUBDIVISION - ROAD PLANS

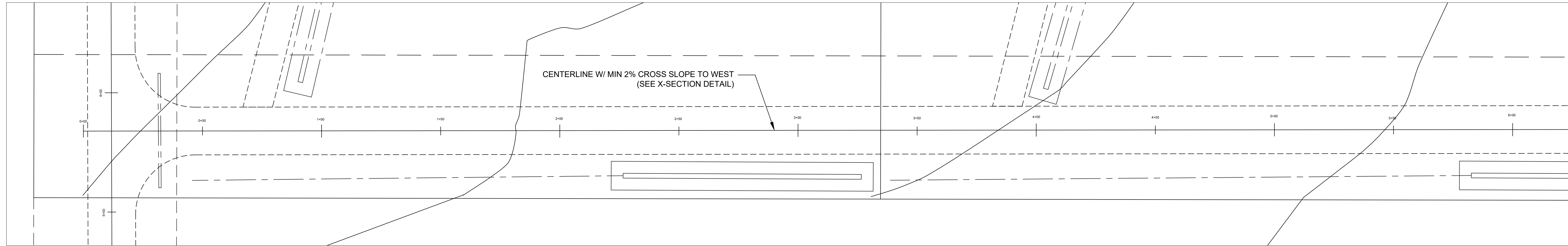

SONGBIRD WAY ROAD PLAN

SCALE: 1" = 20'

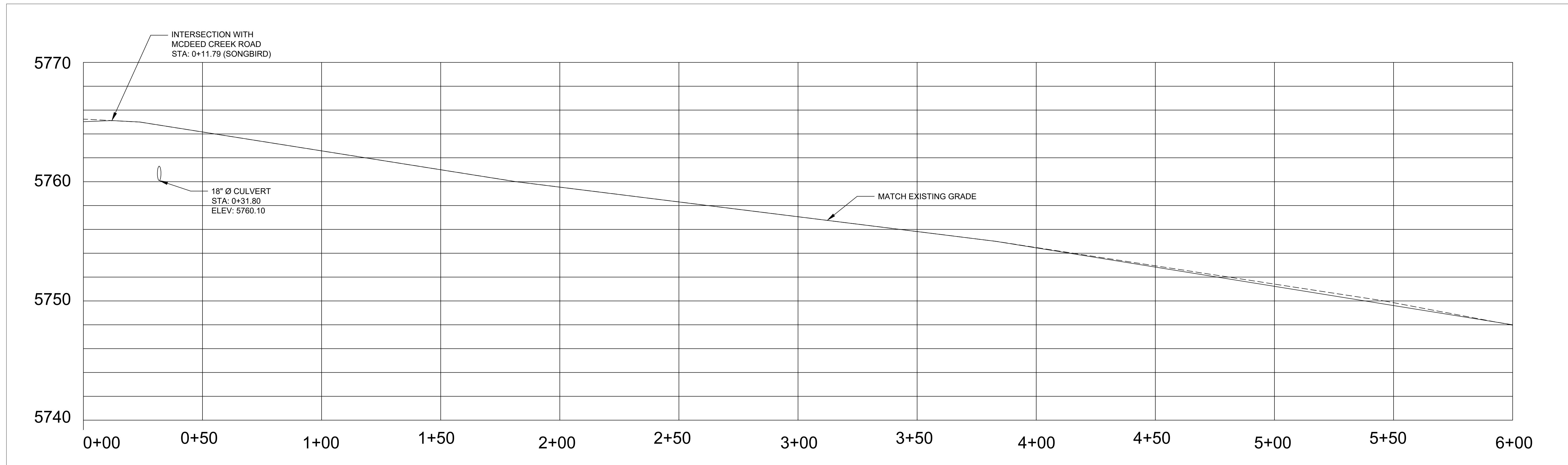

SONGBIRD WAY ROAD PROFILE

HORIZONTAL SCALE: 1" = 20'
VERTICAL SCALE: 1" = 4'

REVISIONS

NO.	DESCRIPTION	DATE	BY	CHECKED BY



P.O. BOX 353
McALLISTER, MT 59740
(406) 570-0341
mkcivilengineering.com

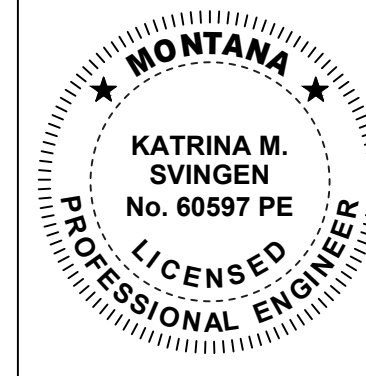

DESIGNED BY
DRAWN BY
DATE
QA / QC
CHECKED BY
DATE

STORTER MINOR SUBDIVISION

MADISON COUNTY, MT

ROAD PLANS

SONGBIRD WAY - STA: 0+00 TO 6+00

PROJECT NUMBER
24-102

SHEET NUMBER
3 OF 5

DRAWING NUMBER

R2.1

STORTER FIRST MINOR SUBDIVISION - ROAD PLANS

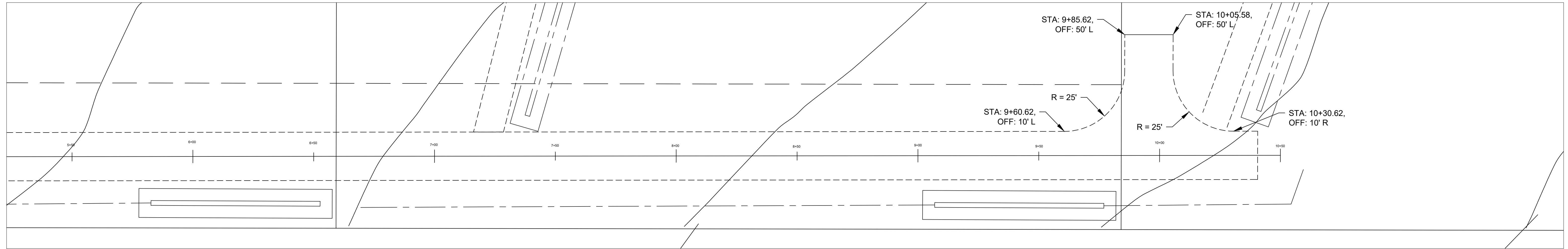

SONGBIRD WAY ROAD PLAN

SCALE: 1" = 20'

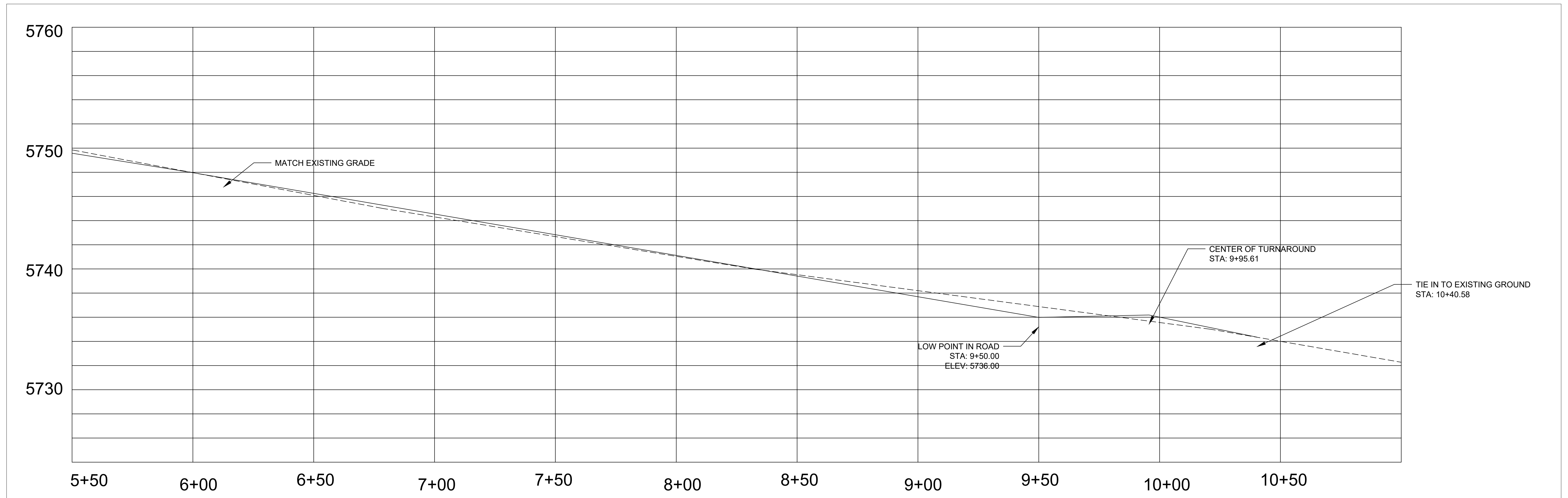

SONGBIRD WAY ROAD PROFILE

HORIZONTAL SCALE: 1" = 20'
VERTICAL SCALE: 1" = 4'

REVISIONS

NO.	DESCRIPTION	DATE	BY	CHECKED BY

MK Engineering

P.O. BOX 353
McALLISTER, MT 59740
(406) 570-0341
mkcivilengineering.com

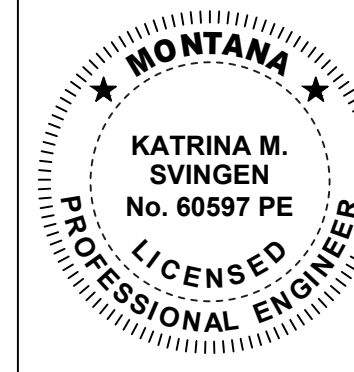

DESIGNED BY
DRAWN BY
DATE
QA / QC
CHECKED BY
DATE

STORTER MINOR SUBDIVISION

MADISON COUNTY, MT

ROAD PLANS

SONGBIRD WAY - STA: 5+50 TO 10+50

PROJECT NUMBER
24-102

SHEET NUMBER
4 OF 5

DRAWING NUMBER

R2.2

STORTER FIRST MINOR SUBDIVISION - ROAD PLANS

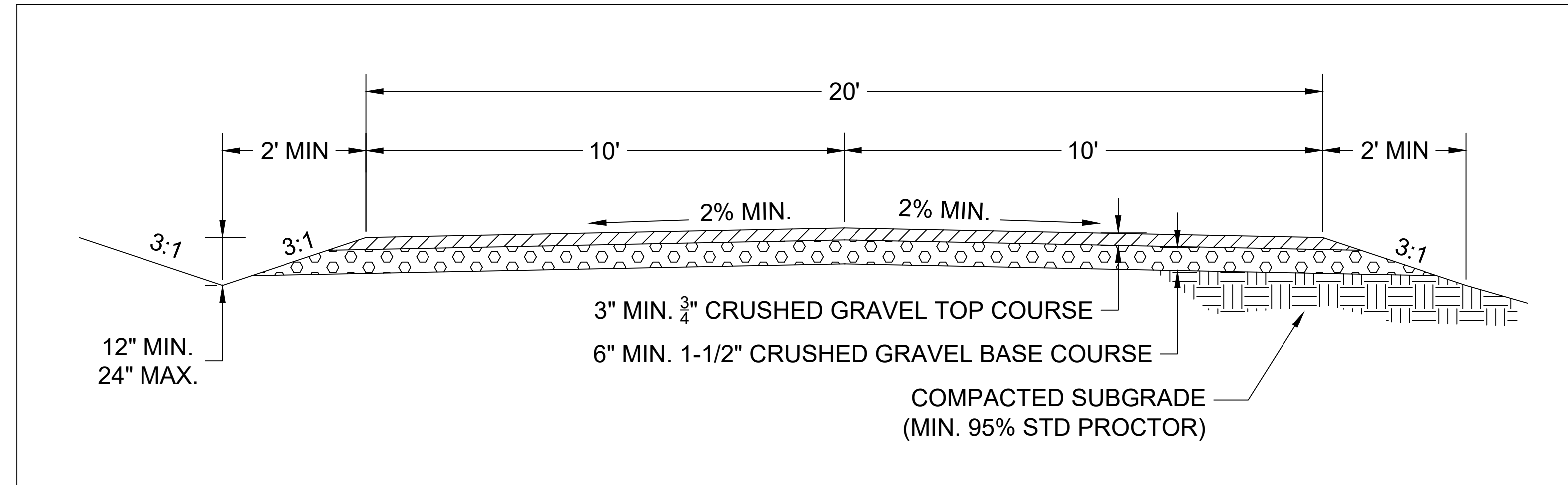

MCDEED CREEK ROAD CROSS SECTION DETAIL

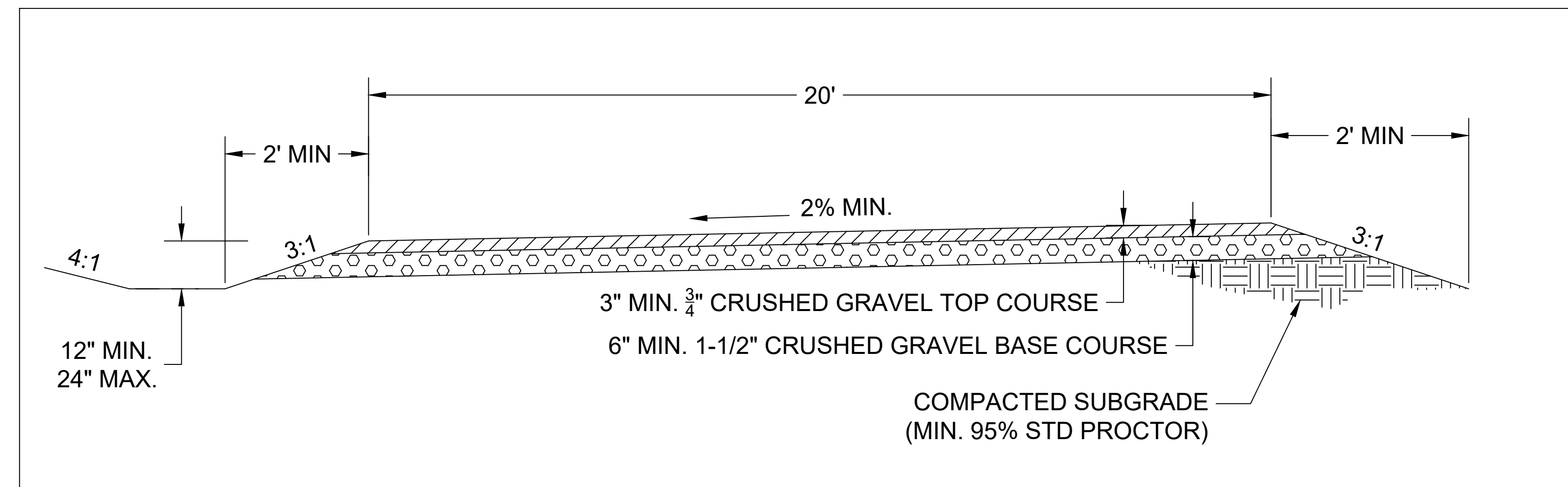

SONGBIRD WAY CROSS SECTION DETAIL

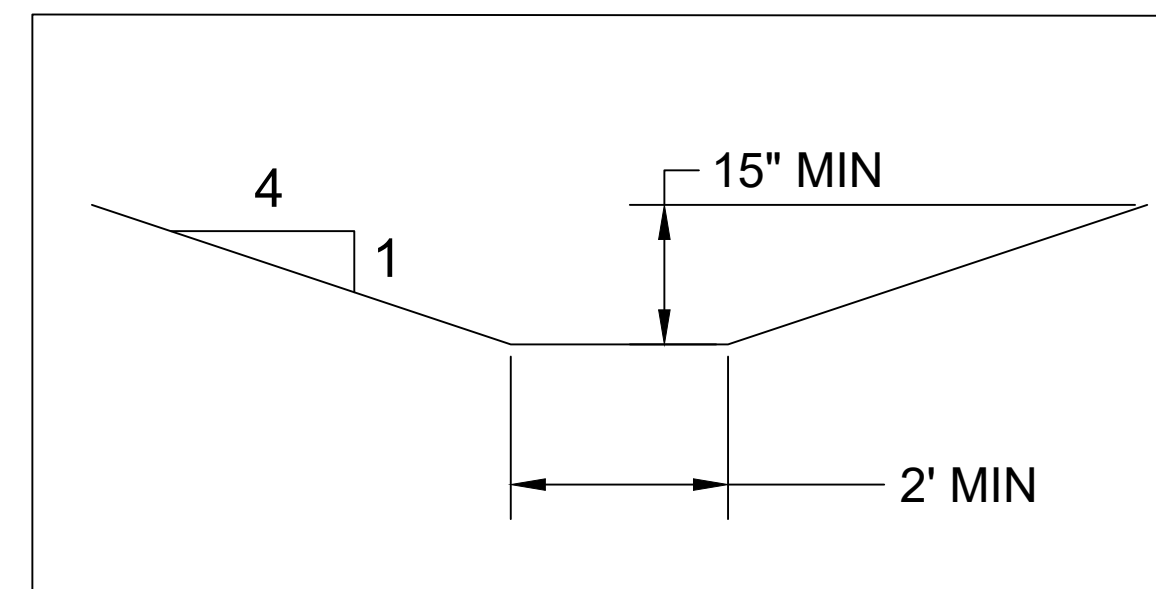

ACCESS ROAD RETENTION POND SECTION

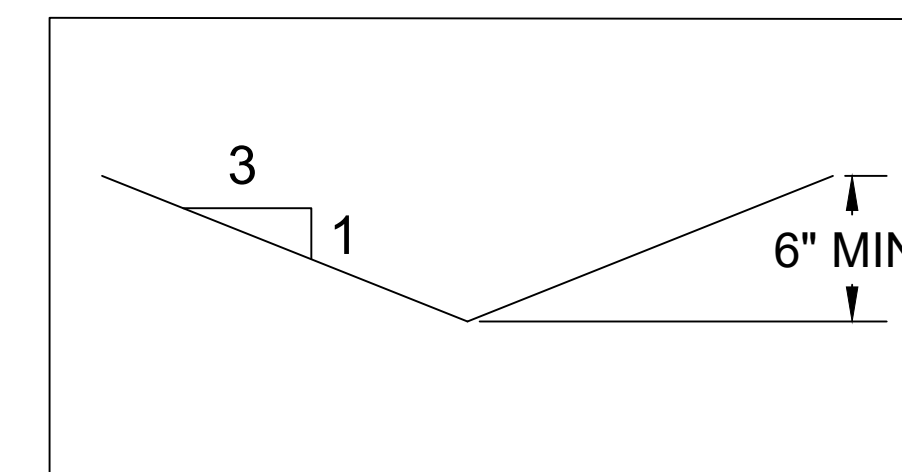

TYPICAL V-DITCH SECTION

REVISIONS

NO.	DESCRIPTION	DATE	BY	CHECKED BY

MK Engineering

P.O. BOX 353
McALLISTER, MT 59740

(406) 570-0341
mkcivilengineering.com

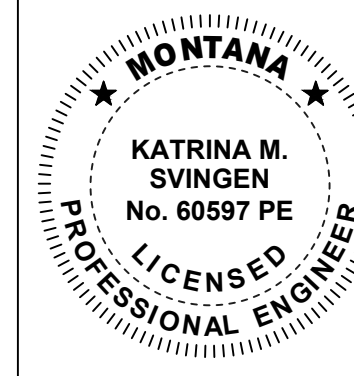

DESIGNED BY	
DRAWN BY	
DATE	
QA / QC CHECKED BY	
DATE	

STORTER MINOR SUBDIVISION

MADISON COUNTY, MT

DETAILS
ROAD DETAILS

PROJECT NUMBER
24-102

SHEET NUMBER
5 OF 5

DRAWING NUMBER

R3.0